

Branch Circuit Power Systems - Metal Fabrication



Metal Fabrication Technical Specifications

Modifying off-the-shelf enclosures in your shop or on the job-site has always been a viable method, but performing alterations under exposed conditions or without adequate tools is an inefficient use of manpower. Predictable and cost effective results require the right skills, equipment, and materials.

Through our years of service to the industry, we have developed production methods and techniques that are adapted to every enclosure we construct. This often allows for production of "Custom" fabricated components at near catalog prices. ACS/Uni-Fab specializes in custom requests.

When you request an evaluation or estimate from ACS/Uni-Fab, you tap a practical solution resource to solve any special enclosure challenge. Our skilled craftsmen and engineers are ready to evaluate your sample, sketch or blueprint. All of our enclosures are built to appropriate safety agency standards.

Here are some of the services we offer:

- Design assistance
- Non-standard and large enclosures
- Boxes built to NEMA standards
- Stainless steel or painted
- Specialty supports, stands and hangers



Metal Fabrication Technical Specifications



Custom Components

On virtually every project, there are specific areas where standard brackets, clamps, plates, spacers, racks, frames, stands and supports just don't work or are not available. Lack of the right component for the job can result in delays and cost you money.

Based on job requirements, needs or application, ACS/Uni-Fab can design or modify the component necessary to solve the problem at hand, with shop drawings for your approval and a prototype, if needed.

Metal Fabrication Technical Specifications

NEMA 4X Enclosure

Options and Modifications:

- Supports, mounting brackets and panels
- Holes or knockouts
- Sizes to meet specifications and requirements
- Mounting base, feet, stands
- Lifting eyes

Our NEMA 4X Stainless Steel Single, Double, and Quad door enclosures are designed to house electrical terminals, instruments, controls, etc. They are intended for indoor or outdoor use, primarily to provide a degree of protection against corrosion, wind blown dust and rain, splashing water and hose directed water.

Construction:

- Made from code gauge, Type 304 Stainless steel with a #3 finish
- Continuously welded seams
- Closed cell neoprene gasket attached with oil resistant adhesive
- Units over 36" wide have double doors, quad units have double doors on opposite sides
- Double door units can have removable center mullion between the two doors to facilitate ease of panel and equipment installation
- Rolled lip on door openings to increase strength and keep liquids from dripping inside when door is open
- Continuous or lift-off hinges
- All stainless steel hardware



Branch Circuit Power Systems - Audio Visual Boxes



Audio Visual Boxes Technical Specifications

Audio Visual Boxes for stadiums, arenas and convention centers.

Description

ACS/Uni-Fab's Audio-Visual boxes are specifically designed for the Audio -Visual Industry.

- 22" wide enclosures accommodate 19" EIA rack panels
- All rails are machined with the EIA universal spacing holes
- Cable Pass Throughs (CPT) with Neoprene Seals are available for cable entry
- Boxes are available in stainless steel with #3 brushed finish or beige textured paint
- 16 gauge stainless steel is used on boxes under 24" in any dimension
- 14 gauge stainless steel is used on boxes over 24" in any dimension

Standard Part Number

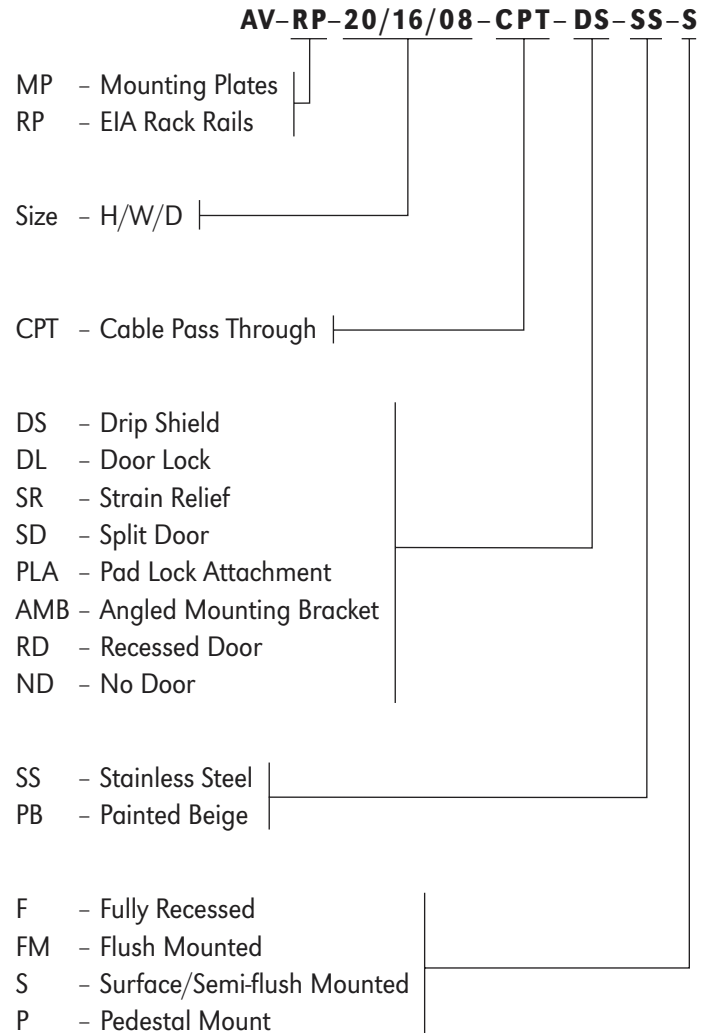

Cable Pass Through

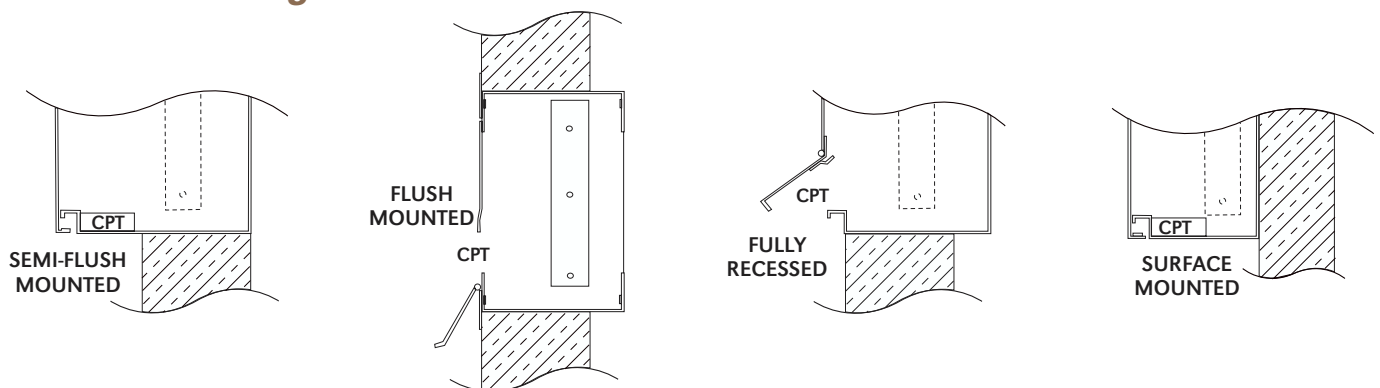

Branch Circuit Power Systems - Copper Bus

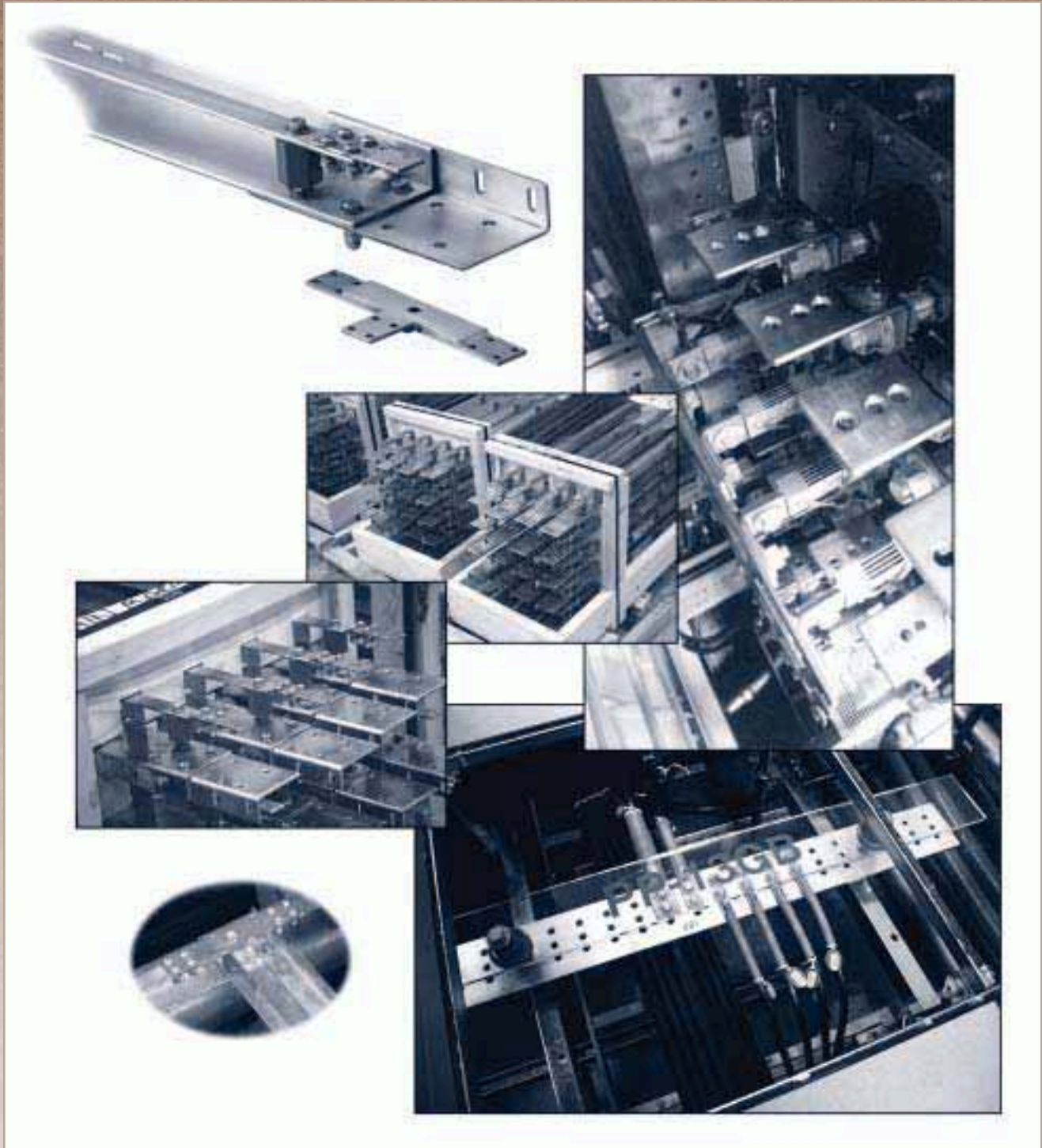

Copper Bus Technical Specifications

ACS/Uni-Fab excels in fabrication of copper bus bars and sheet components. Using contractor specifications, we will build the copper components necessary for each application...new, repair or modification. The fabrication of these components, (breaking, cutting, drilling, milling, punching, shaping, tapping, welding, etc.) will take place in one of our automated machine shops under the supervision of skilled technicians, assuring the quality you expect.

Materials Available:

- Rectangular copper bus bar with square or round edges in 1/8" to 2" thick, 3/8" to 8" wide, up to 12' long
- Copper sheet 12 oz. to 1/2" thick, 36" to 48" wide, up to 10' long (other sizes are available on request)
- Insulators and Stand-offs available

Applications:

- Ground bars
- Panel bus bars (for repair, modification, etc.)
- Bus systems
- Bus brackets, clips, and stand-offs
- Transient suppression plates
- Shielding
- Frame ground straps
- Assemblies (including insulators and/or plexi-glass shields)
- Kits (including lugs, mounting hardware, etc.)
- Tap box assemblies

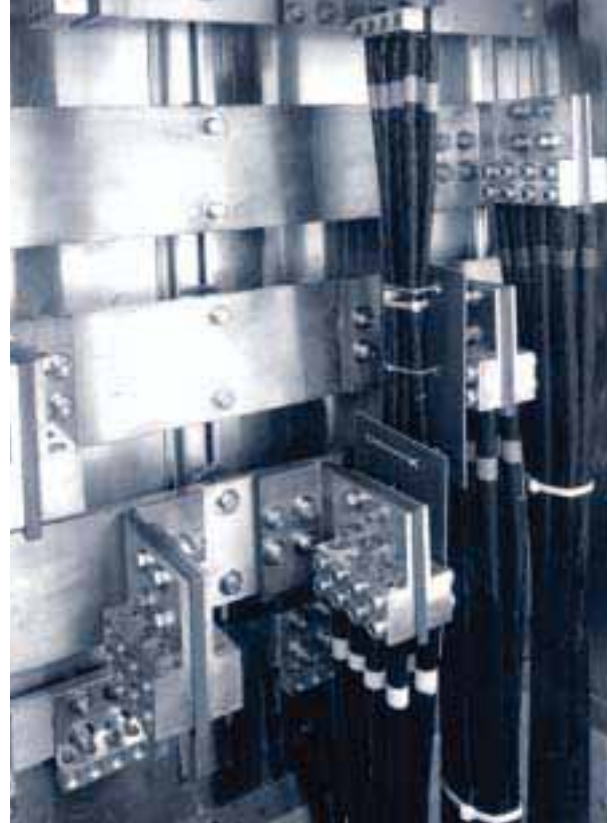

Branch Circuit Power Systems - Cable Trough

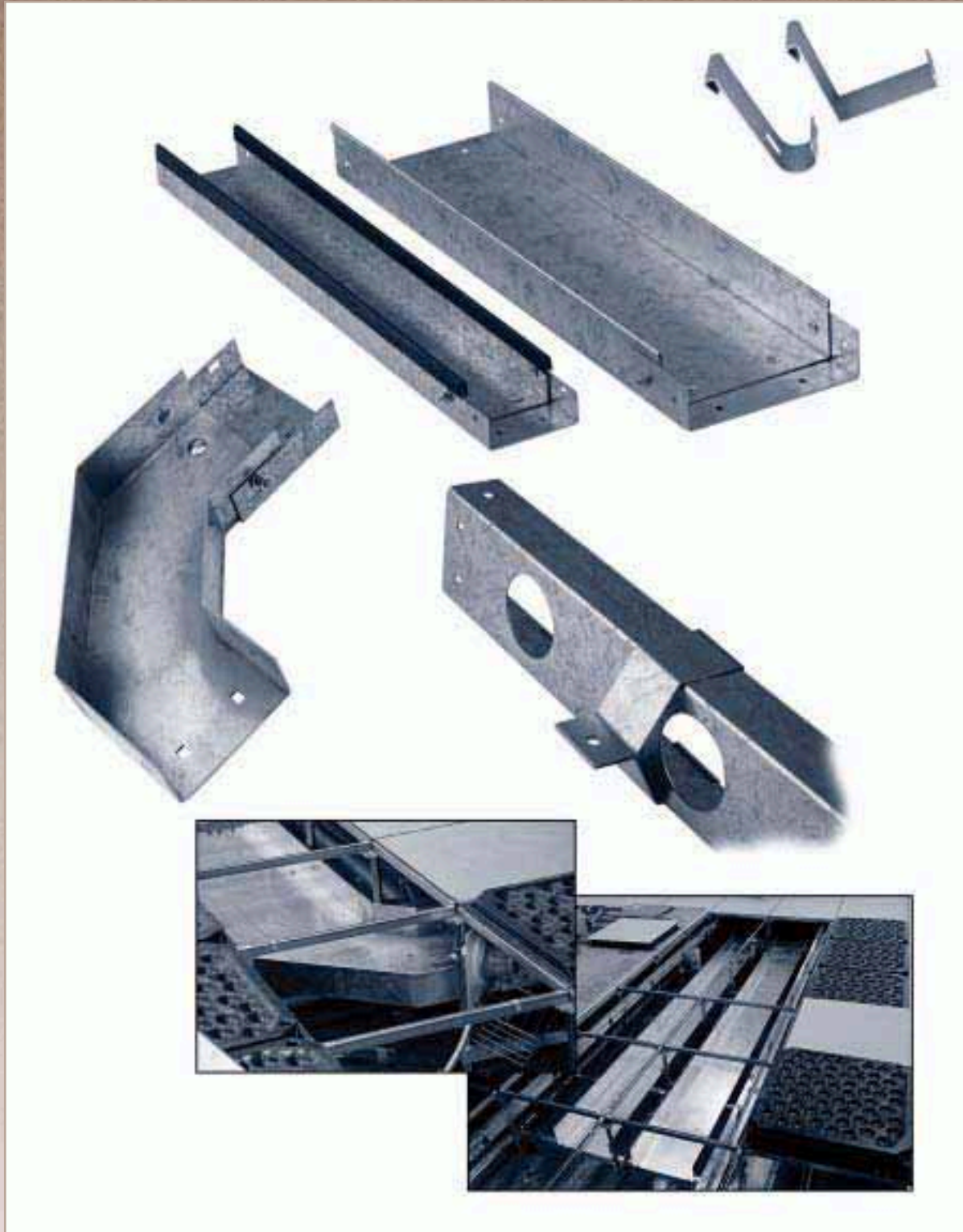

Cable Trough Technical Specifications

Cable Trough

Cable Trough is designed as a cable management and support system for armored and jacketed cables. Trough is available in a variety of dimensions and edge configurations. These features allow it to be custom fitted to a multitude of applications.

The trough is constructed of 16 gauge galvanized steel, which offers strength at an economical price.

Three versions are available:

- Sheared Edge – Recommended for use with armored cable in a High-bay application where the cable installation is intended to be permanent.
- Hemmed Edge – Recommended for use with both jacketed and armored cable in ceiling and raised floor applications where the cables are periodically changed, moved, draped over the edge, or where technicians are in contact with the Trough on a frequent basis.
- Grommetted Edge – Sheared Edge Trough with a grommet added for uses similar to those for the Hemmed Edge Trough. The grommet can be added in specific areas only, or as a complete system.

The bottom of the standard trough is solid and smooth for easy cable pulling.

Drop Outs can be added to allow the cable to drop through the bottom of the trough instead of going over the edge.

When ordering, include the desired diameter and frequency of openings. Drop Outs can be grommetted upon request.

Weep Holes can be added in the trough bottom when drainage is a requirement.

Standard mounting hardware is electroplated zinc. Stainless steel hardware is available on request.



Cable Trough Technical Specifications

The Trough Tap allows smaller size Taps to intersect the main trough where:

- Dimensional information is not available
- Field tolerances are questionable
- Flexibility is required

The Tap covers all internal filed cut edges which might damage cable.

The Tap fits into an opening cut in the field using a Tap Template. Tap Templates are designed to each projects specifications to assure accurate opening placement.

Note: All 1600 Series products are 16 gauge (1.5mm) Galvanized steel.
Zinc electroplated hardware is standard.
Stainless is available at additional cost.

Cable Trough - 1600 Series

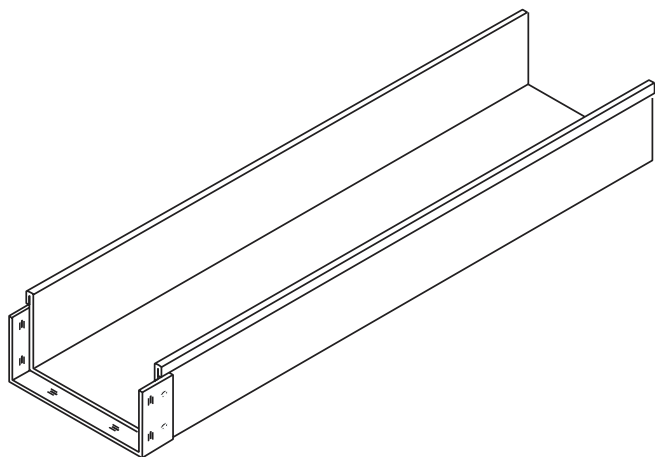

Cable Trough - 1600 Series

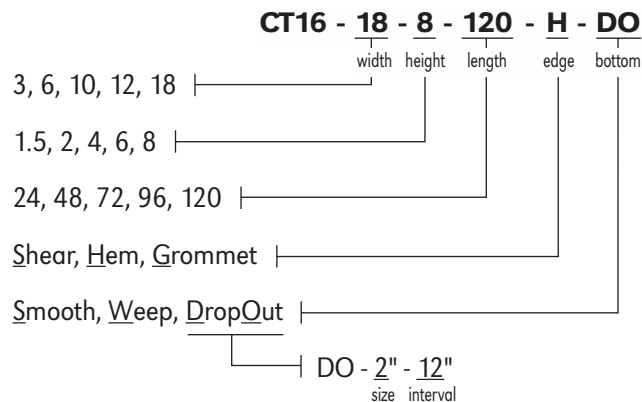

Cable Trough "Taps"- 1600 Series

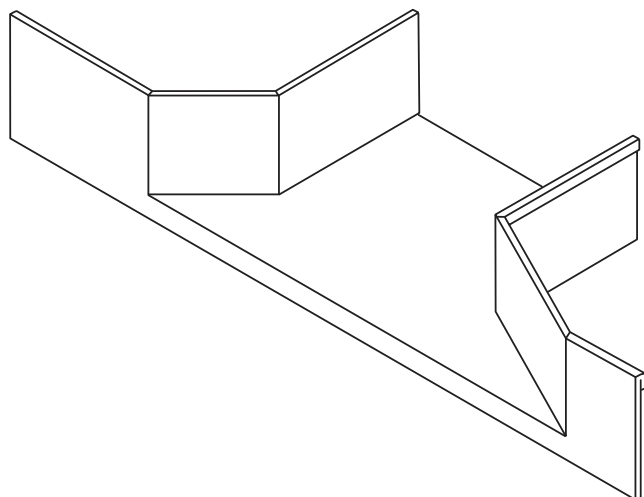

Cable Trough - Taps

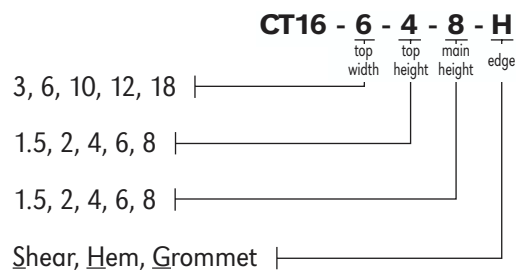

Cable Trough Technical Specifications

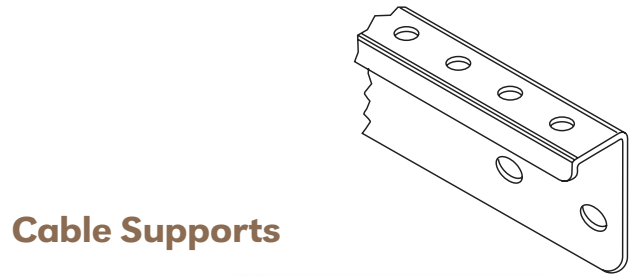
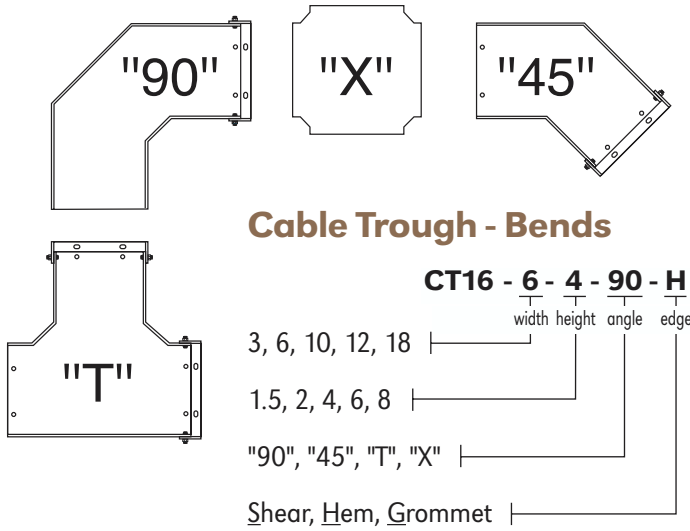

Cable Supports

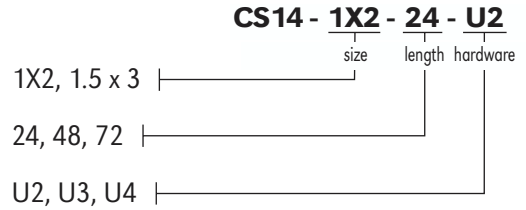

Cable Trough - Ramp Fitting

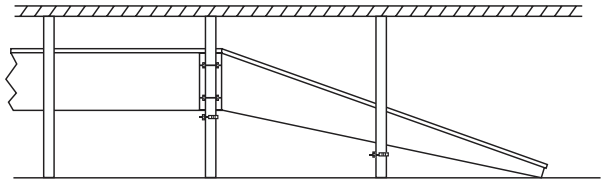
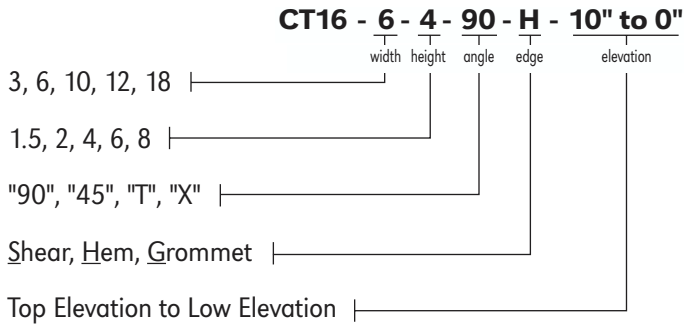

Cable Trough - Supports

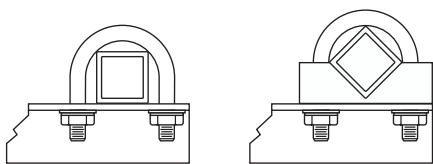
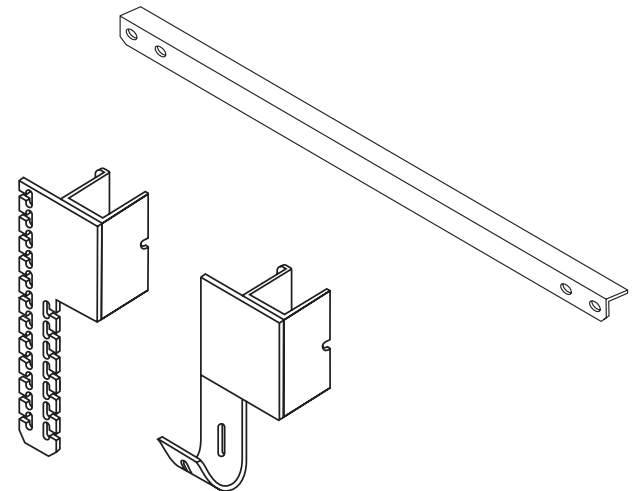
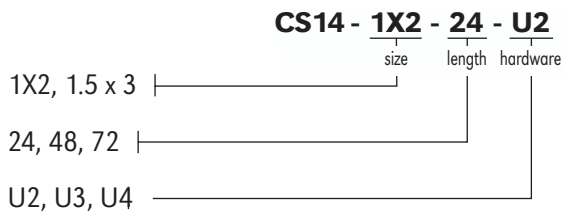

Note: All 1600 Series products are
 16 gauge (1.5mm) Galvanized steel.
 Zinc electroplated hardware is standard.
 Stainless is available at additional cost.